

Revisions			
Issue	Description	Drawn	Checked

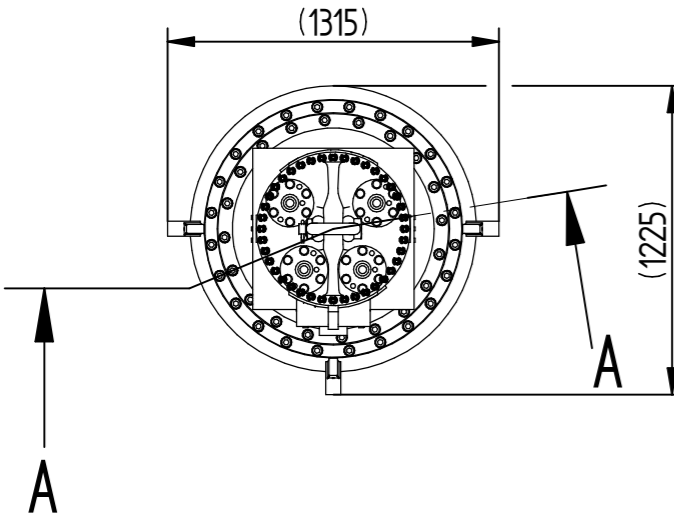

86255050
G-4163 Green Pin Std. Shackle
WLL 25T

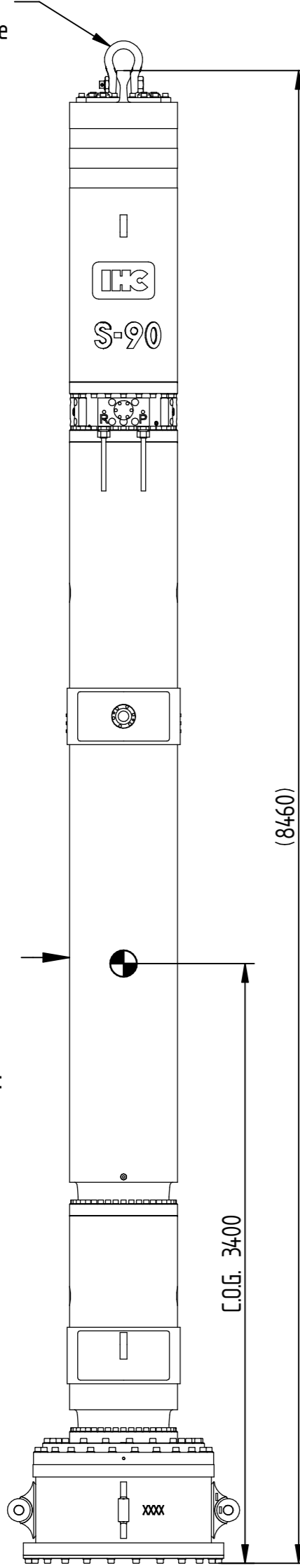

85110007_DH
s/n 11KT90B117
s/n 11KT90B118
Conversion set (-5m):
(85118812)

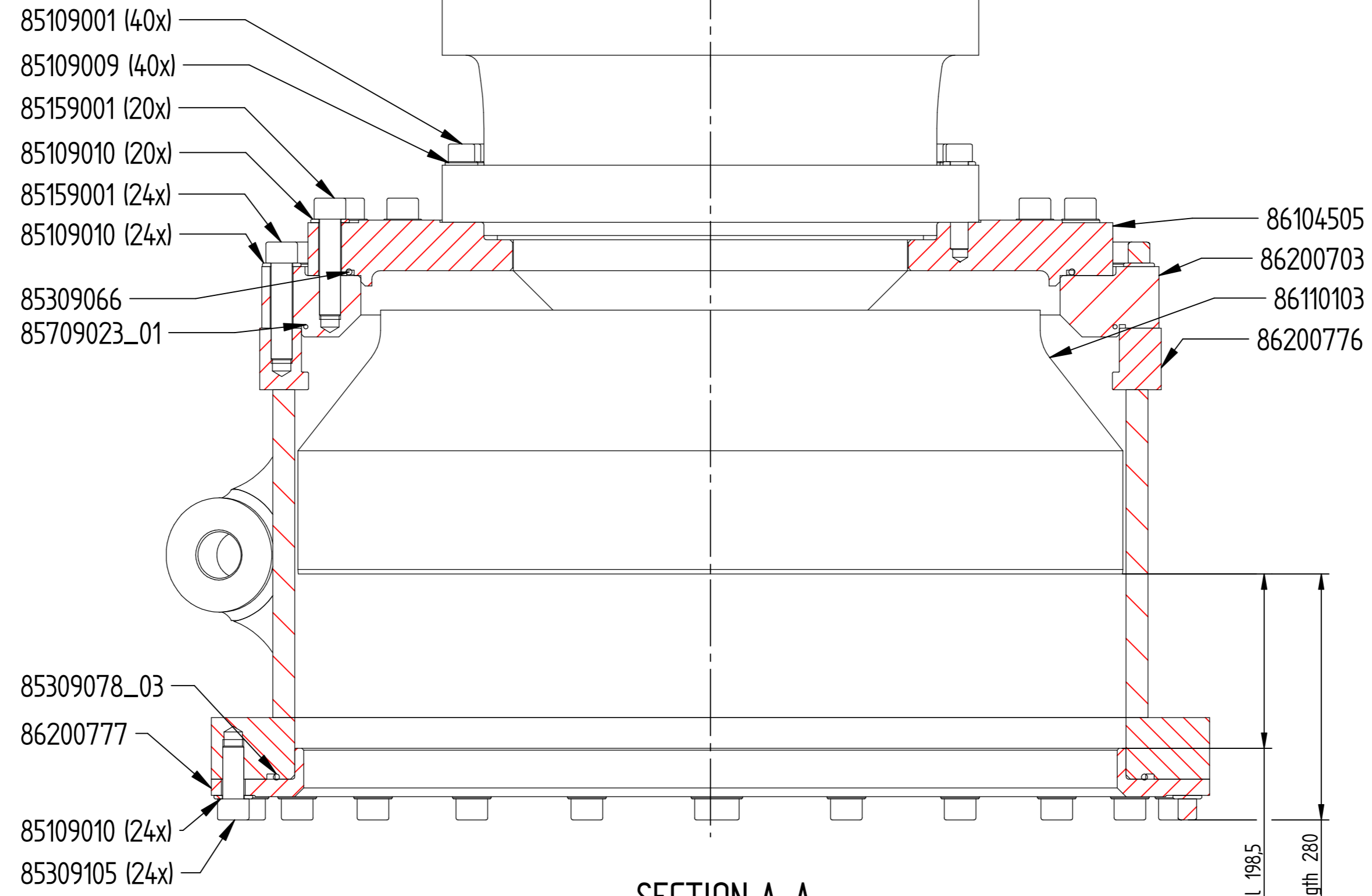

SECTION A-A
1:5

Stick-up length with different hydrohammers	
Hammer	Stick-up Length (mm)
S-30/40	280
S-70/90	280
S-120/150	261,5
S-200/280	256,5

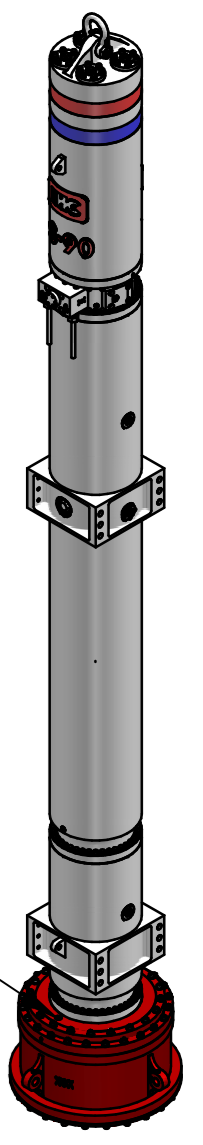

torque values for screws and bolts acc. to 85995001

Part No.	QTY	Subject	Dimensions
86255050	1	Shackle	WLL 25T
86200777	1	Pile guiding ring 36 inch	φ1135 x φ925 x 55
86200776	1	Anvil housing 36 inch (short)	1315 x 1225 x 513
86200703	1	Connection ring sleeve 36"	-
86110103	1	slagplaat	-φ938 L=300
86104505	1	aanbouwing	-φ915 x φ450 d=75;
85709023_01	1	O-ring	-φ915x5;
85309105	24	Socket head screw	-DIN 912 M24x60
85309078_03	1	Rubber cord φ7	φ980 L=3080
85309066	1	O-ring	-φ815xφ7
85159001	44	Socket head screw	-DIN 912 M24x110
85110007_DH	1	Hydrohammer® S-90	
85109014	1	Plug	-R 3/4"
85109010	68	HV-ring	ISO 7416 φ 25
85109009	40	HV-ring	-ISO 7416 φ 21
85109001	40	Socket head screw	-DIN 912 M20x100
Document Nr.	QTY	Subject	Dimensions

Lower out anvil 198,5
Stick-up length 280

Copyright of IHC Merwede whose property this document remains. No part thereof may be disclosed, copied, duplicated or in any other way made use of except with the approval of IHC Merwede

Drawn: CvM Date: 16-07-2014
Checked: VvdG Date: 21-07-2014
Scale: 1:30

Welding:
Welded constr. acc. EN 13920-B/F:1996
Symbols acc. ANSI/AWS 2.4:2007

Machining:
Tolerances acc. EN 22768-m/K:1993
Form and position tol. acc. ISO 1101:2006
Surface roughness acc. ISO 1302:2002

IHC MERWEDE IHC Hydrohammer B.V.

Title: S-90 + sleeve 36" (short)
S-90 + sleeve 36" (kort)

Change Request: 13682
Drawing no: P_004111
Issue: -
Size: A2
Sheet 1 of 2

RELEASED FOR PRODUCTION

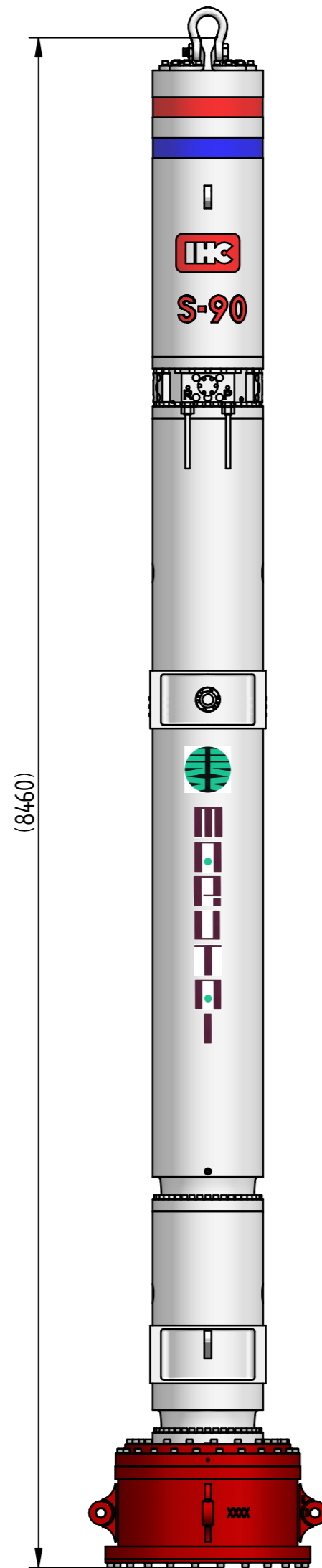
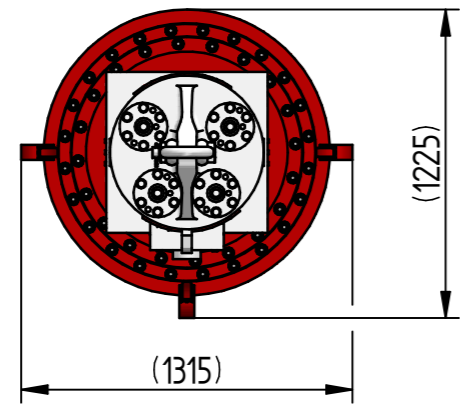

Revisions				
Issue	Description	Drawn	Date	Checked Date

Copyright of IHC Merwede whose property this document remains. No part thereof may be disclosed, copied, duplicated or in any other way made use of except with the approval of IHC Merwede

Drawn: CvM Date: 16-07-2014

Checked: VvdG Date: 21-07-2014

Scale: 1:30



IHC Hydrohammer B.V.

Welding:
Welded constr. acc. EN 13920-B/F:1996
Symbols acc. ANSI/AWS 2.4:2007

Title: S-90 + sleeve 36" (short)
S-90 + sleeve 36" (kort)

Machining:
Tolerances acc. EN 22768-m/K:1993
Form and position tol. acc. ISO 1101:2006
Surface roughness acc. ISO 1302:2002

Change Request:
13682
With Ref. of:

Drawing no:
P_004111

Issue: -
Size: A2

Sheet 2 of 2

RELEASED FOR PRODUCTION